

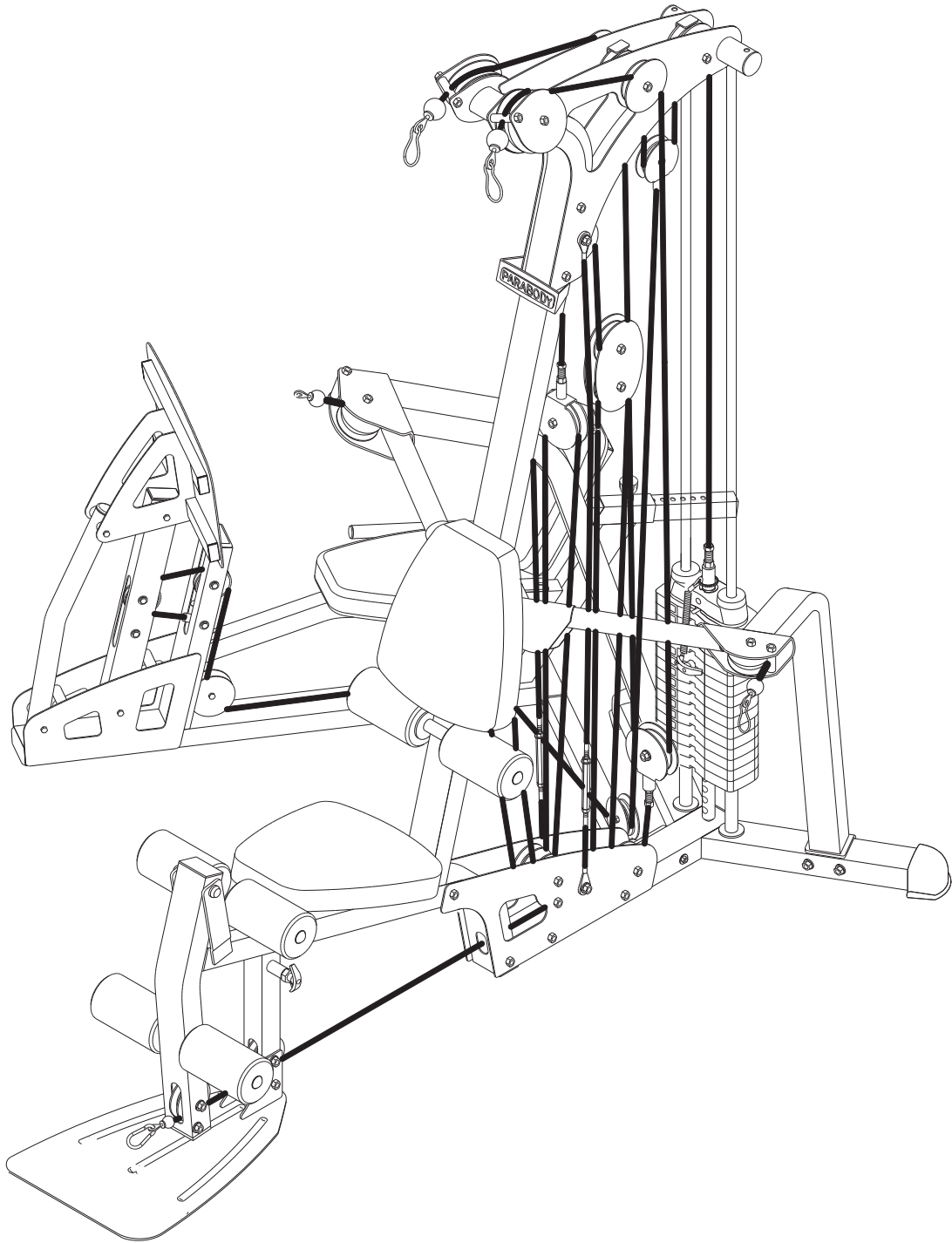

G3-GLPA-001  
G3 HOME GYM LEG PRESS ADAPTER



Customer Support Services  
PARTS MANUAL

# G3-GLPA LEG PRESS ADAPTER CONTENTS

---

	PAGE
COMPONENT ASSEMBLY I	3
COMPONENT ASSEMBLY II	4
COMPONENT ASSEMBLY III	5
SUPPLIED ACCESSORIES	6
HARDWARE BAG	7

# G3-GLPA LEG PRESS ADAPTER COMPONENT ASSEMBLY I

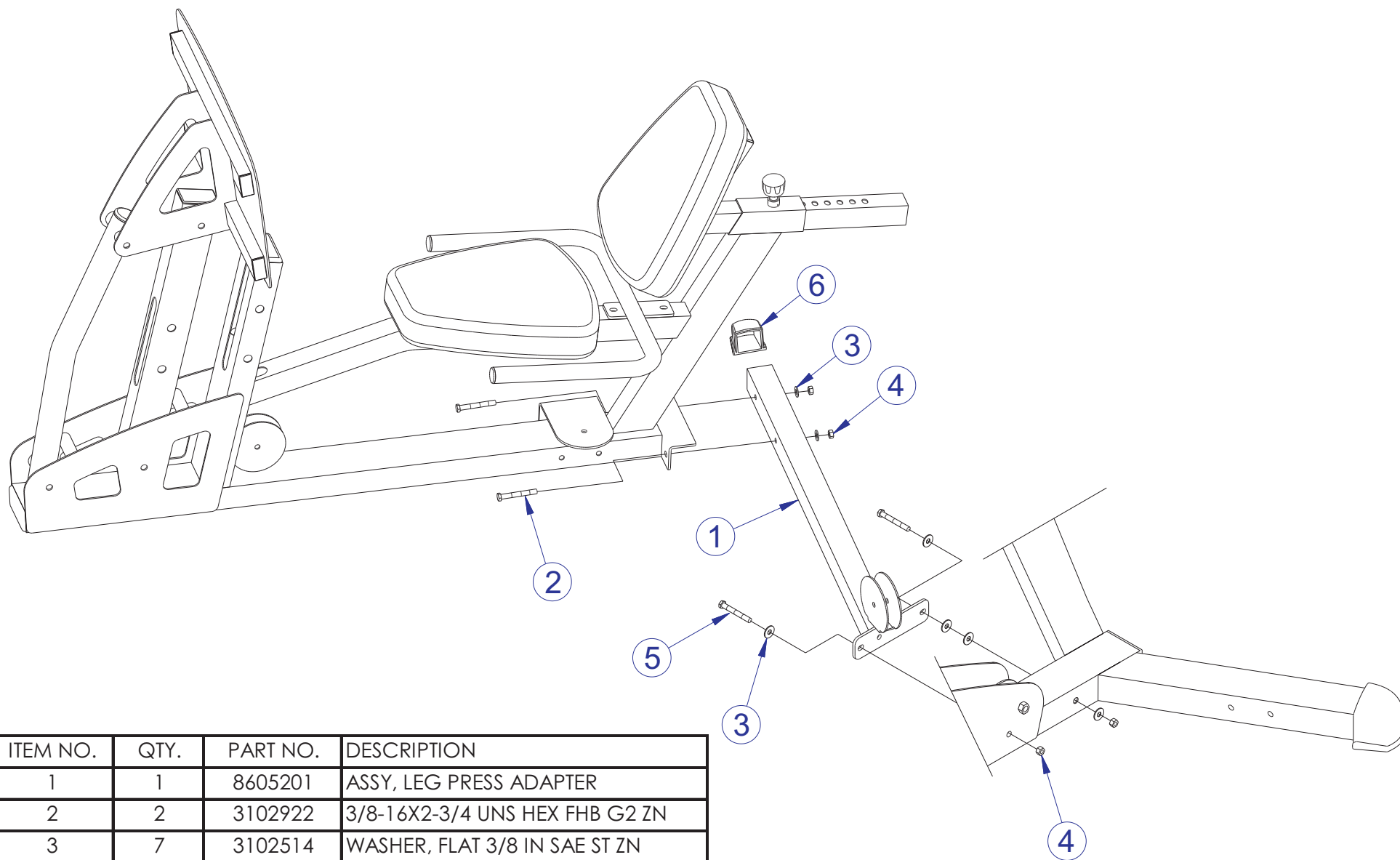

ITEM NO.	QTY.	PART NO.	DESCRIPTION
1	1	8605201	ASSY, LEG PRESS ADAPTER
2	2	3102922	3/8-16X2-3/4 UNS HEX FHB G2 ZN
3	7	3102514	WASHER, FLAT 3/8 IN SAE ST ZN
4	4	3102802	VMI NUT, NYLOCK 3/8-16
5	2	3102906	3/8-16X4 UNS HEX FHB G2 ZN
6	1	8582701	CAP, COVER 2 X 2

# G3-GLPA LEG PRESS ADAPTER COMPONENT ASSEMBLY II

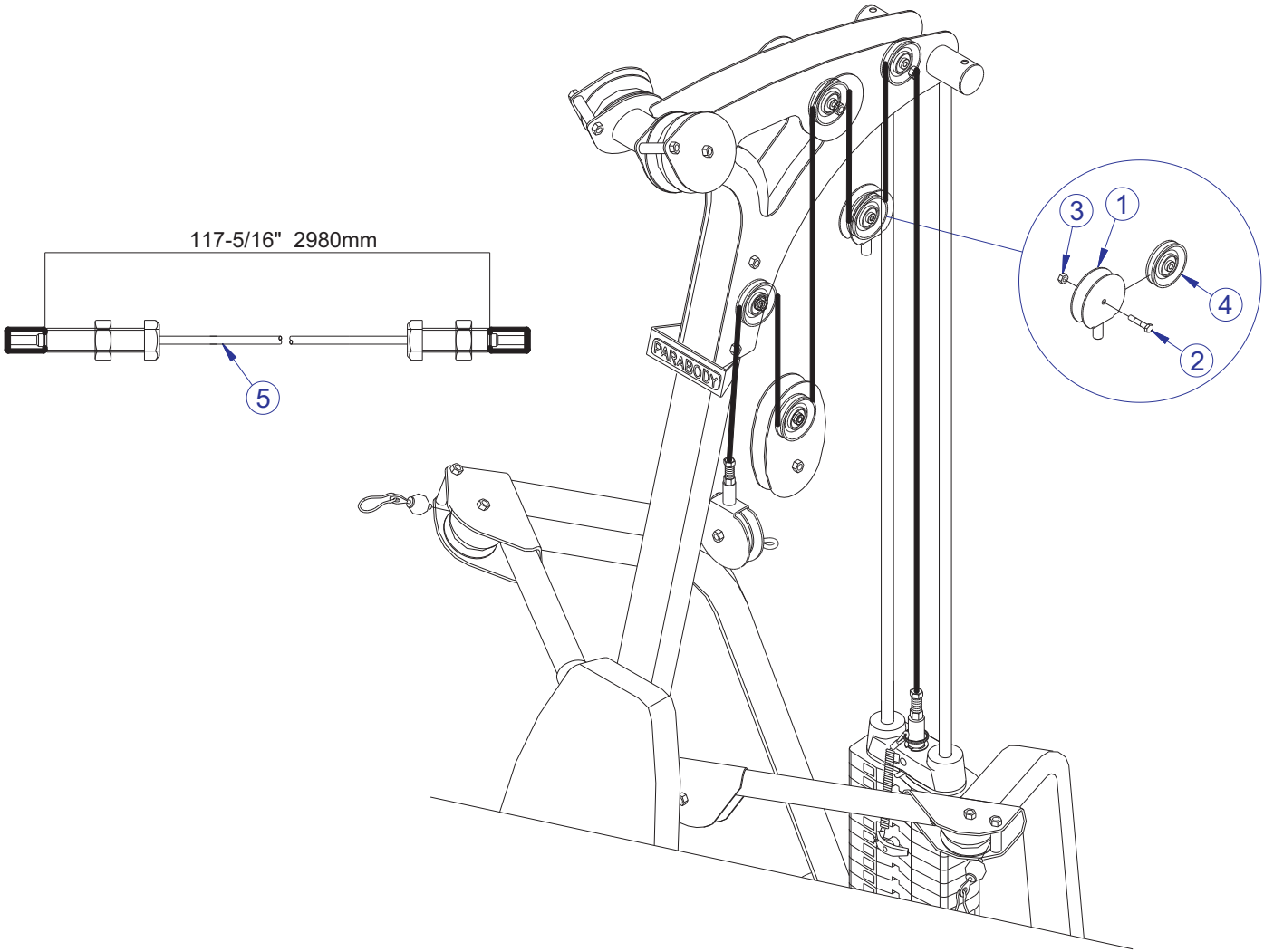

ITEM NO.	QTY.	PART NO.	DESCRIPTION
1	1	8597301	BRKT, FLOATING PULLEY
2	1	3102924	3/8-16X1-3/4 UNS HEX FHB G2 ZN
3	1	3102802	VMI NUT, NYLOCK 3/8-16
4	1	3116201	PULLEY, 3-1/2 OD X 3/8 ID X 1
5	1	8608301	CABLE, WEIGHT STACK, G3-GLPA

# G3-GLPA LEG PRESS ADAPTER COMPONENT ASSEMBLY III

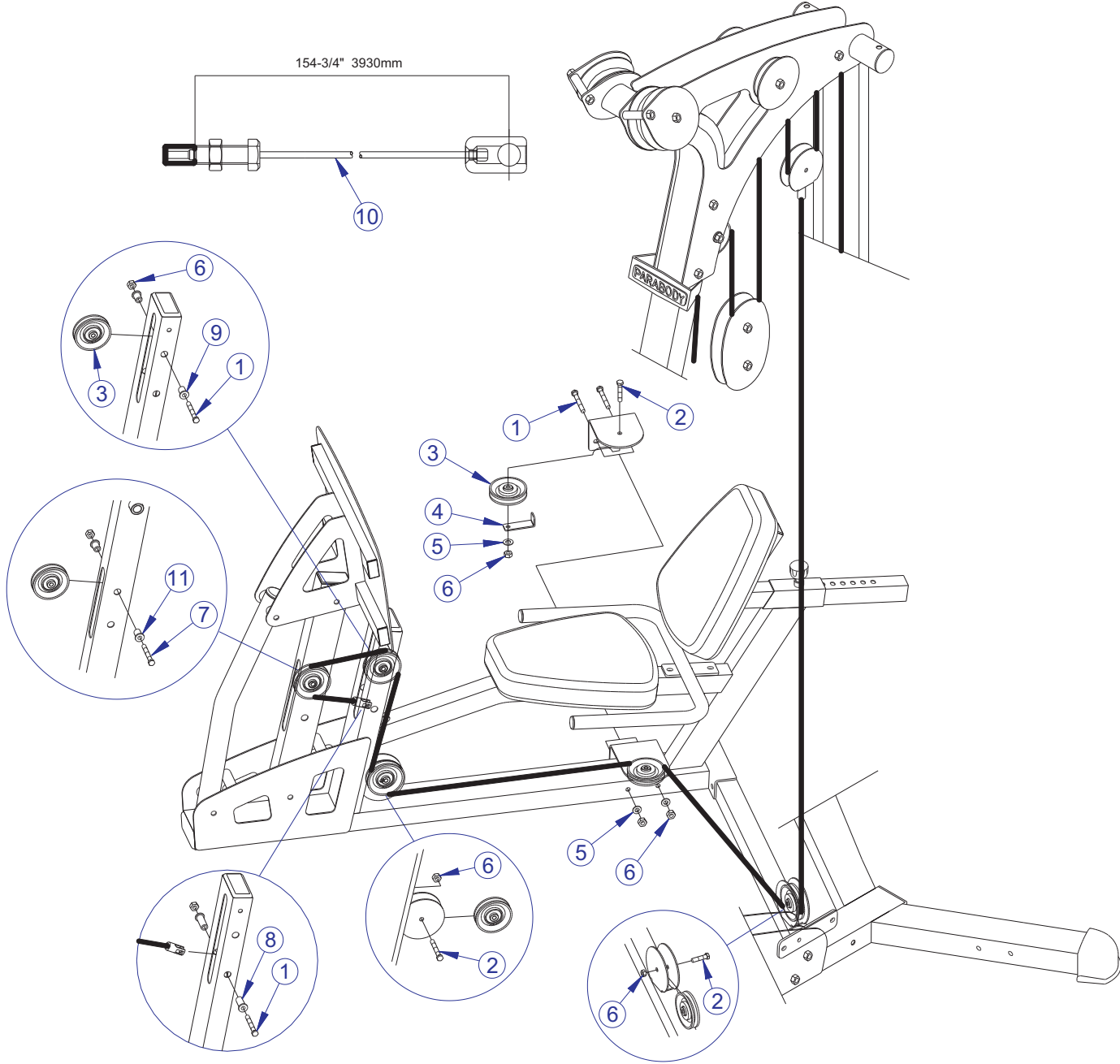

ITEM NO.	QTY.	PART NO.	DESCRIPTION
1	4	3102922	3/8-16X2-3/4 UNS HEX FHB G2 ZN
2	3	3102924	3/8-16X1-3/4 UNS HEX FHB G2 ZN
3	6	3116201	PULLEY, 3-1/2 OD X 3/8 ID X 1
4	1	8603501	L CABLE RETAINER
5	3	3102514	WASHER, FLAT 3/8 IN SAE ST ZN
6	8	3102802	VMI NUT, NYLOCK 3/8-16
7	1	3102922	3/8-16X2-3/4 UNS HEX FHB G2 ZN
8	2	8607101	SPACER, STEP 11/16
9	2	8607001	SPACER, STEP 1-19/32
10	1	8608401	CABLE, LEG PRESS, G3-GLPA
11	2	8606901	SPACER, STEP 19/32

# G3-GLPA LEG PRESS ADAPTER SUPPLIED ACCESSORIES

1

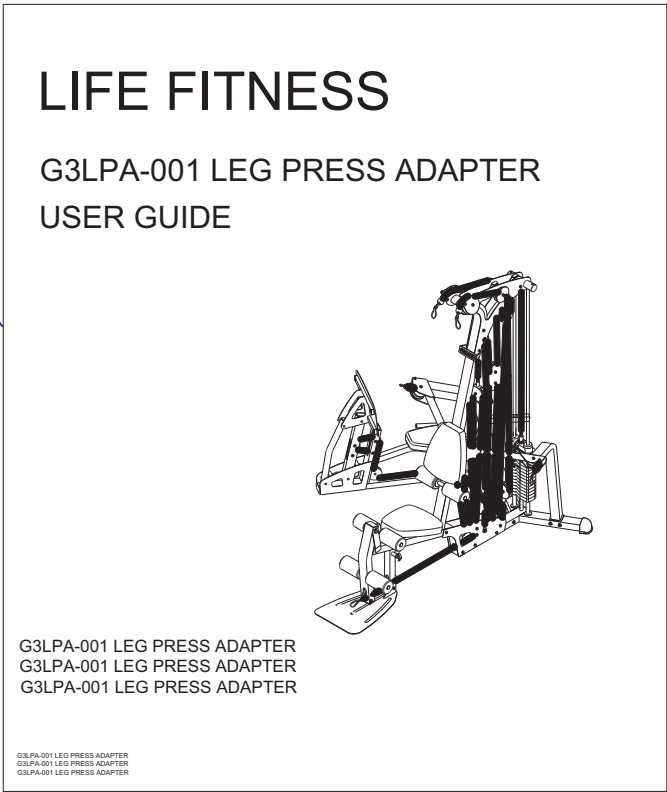

2

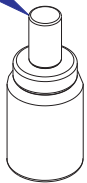

ITEM NO.	QTY.	PART NO.	DESCRIPTION
1	1	8608001	MANUAL, USER'S, G3-GLPA
2	1	8598401	PAINT, TOUCH UP, PLATINUM

# G3-GLPA LEG PRESS ADAPTER HARDWARE BAG

---

## HARDWARE BAG PART NUMBER

8610201

### BAG CONTAINS:

Item	Description	UOM	Quantity
3102972	.375-16 X 4.75 HEX HEAD BOLT	EA	4
3102906	3/8-16X4 UNS HEX FHB G2 ZN	EA	2
3102922	3/8-16X2-3/4 UNS HEX FHB G2 ZN	EA	3
3102924	3/8-16X1-3/4 UNS HEX FHB G2 ZN	EA	4
3102514	WASHER, FLAT 3/8 IN SAE ST ZN	EA	10
3102802	VMI NUT, NYLOCK 3/8-16	EA	13
8606901	SPACER, STEP 19/32	EA	2
8607001	SPACER, STEP 1-19/32	EA	2
8607101	SPACER, STEP 11/16	EA	2